

## DESCRIPTION

The 92 Series of plateclamps can be used on all hotrolled structural steel plates and sections up to a surface hardness of 300 Brinell. They can be used to lift plate from the horizontal to vertical position and vice versa through 180 degrees. The necessary grip required to lift a plate is achieved by increasing the force applied to the clamp from the lifting sling by a system of links. The gripping force is proportional to the load lifted and self-actuating, the greater the load applied to the clamp the greater the gripping force. To initiate the self-actuating force a spring is incorporated into the clamp to give an initial bite on the material. When the load is applied the jaw teeth bite into the plate effectively becoming one with the material and allowing a safe lift. If the plate should start to slip the cam shape of the jaw turns with the material and increases the gripping force. This range is fitted with a hold open and lock closed device.

## DIAGRAM

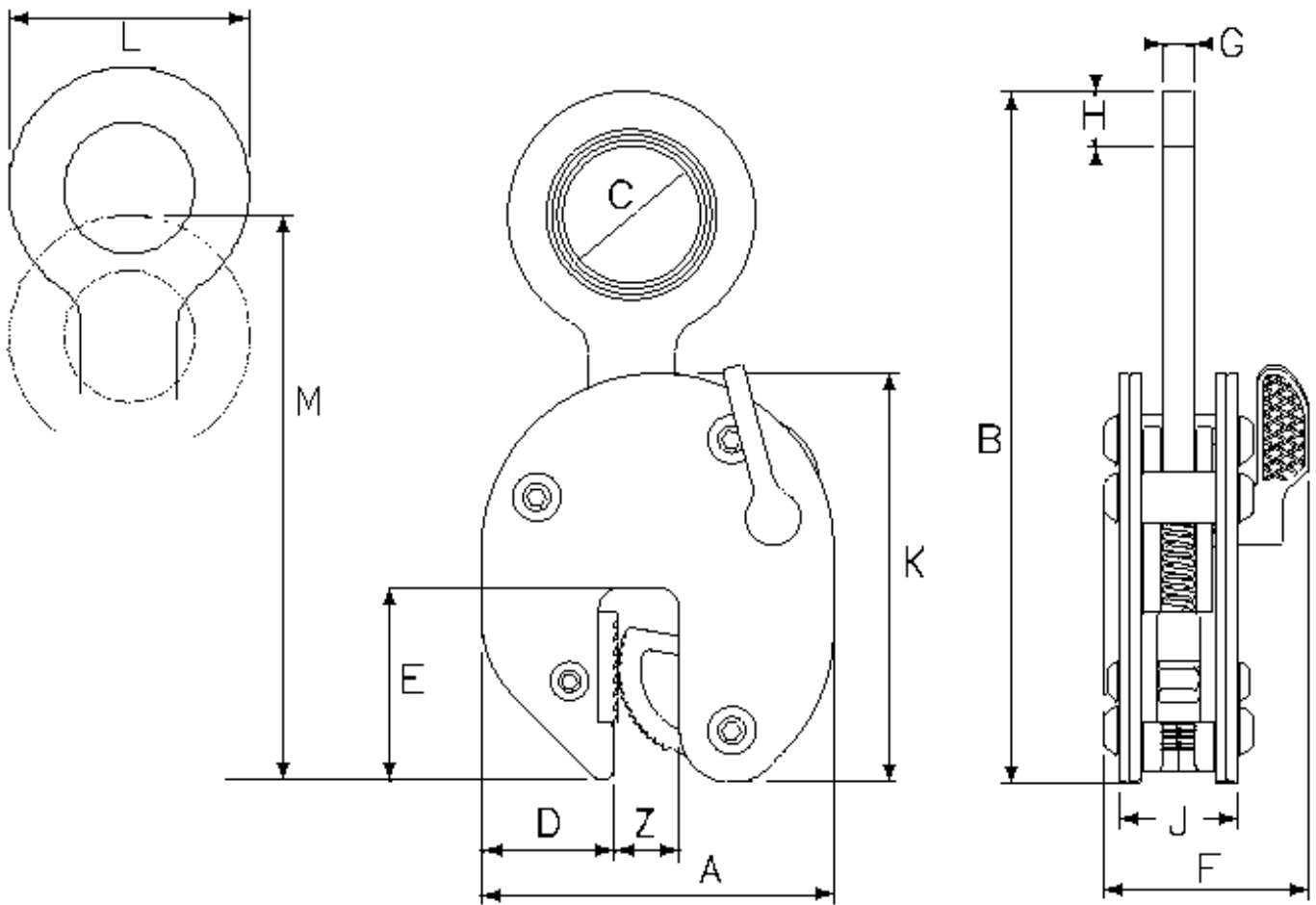

## TABLE

MODEL	WLL Tons	Plate mm Z	Weight kg	A	B	C	D	E	F	G	H	J	K	L	M
CZ921.5	1,5	0 - 20	30	126	225	50	49	70	58	20	20	53	150	90	205
CZ922	2,0	0 - 32	8	192	312	80	75	96	85	20	24	79	210	128	287
CZ923	3,0	0 - 32	10	192	312	80	75	96	85	30	24	79	210	128	287

## Load Diagram with slings vertical

Loads weighing the maximum W.L. may be lifted and turned through 180 degrees in the plane of the clamp

Load must hang no more than shown in diagram when suspended by the clamp only.

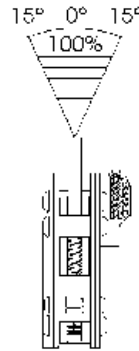
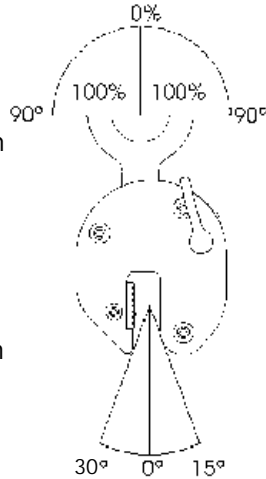

Loads weighing the maximum W.L. may be lifted through 15 degrees in the plane of the clamp

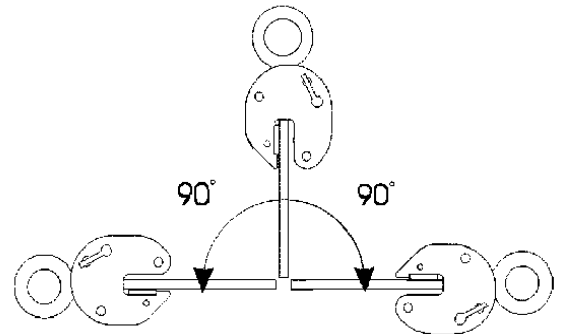

## RESTRICTIONS

The clamp is not suitable for steel over 300 Brinell, stainless steel, lead, certain grades of copper and materials over 120° surface temperature. The working load limit of the clamp should be as close as possible to the actual load to be lifted. This ensures that the clamp is working at maximum efficiency. Loads below 20% of the working load limit should be avoided extra care must be taken when lifting plates in the lower 20% of the rated jaw capacity. Excessive wear and reduction in working life can be caused if a clamp is continuously used to lift the same thickness material.

### FOR SHORT PLATES

A single clamp can be used

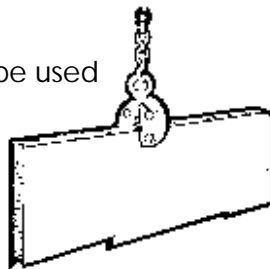

### FOR LONG PLATES

2 clamps and a lifting beam must be used

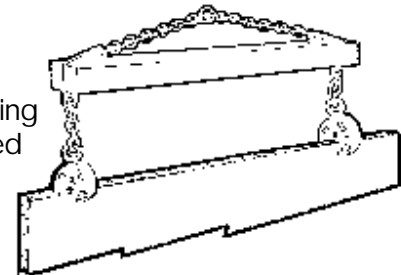

## OPTIONS The Cz92 range of clamps can also be supplied with alternative throat sizes

The narrow throated clamp has been developed for lifting thin light sheets. The pad side is moved closer to the moving jaw, this increases the initial grip of the clamp by causing the spring to be stretched more. e.g. CZ921.5/NT 0 - 10

A large throated clamp is created by moving the pad side away from the moving jaw. This has the advantage that the clamp has a jaw and mechanism best suited to the load applied and therefore is working at maximum efficacy. e.g. CZ921.5/L 20-40

### Cz92/C with chain & master link

The standard clamp is fitted with a hooking which can be replaced with a short length of chain and master link. This aids in the attachment to larger crane hooks and prevents accidental release when fast lowering.



### Cz92/P with chain lock

The standard cam operated locking mechanism can be replaced with a chain pull locking system

